

Temperature range: **+4°C/+6°C**

Refrigerating unit: **Internal**

Refrigerant/Cooling factor: **R448A / R449A**

Name	WySPA Fresh 150	WySPA Fresh 185
Code	FR150	FR185
Length [mm]	1500	1850
Height [mm]	1540+/10	1540+/10
Depth [mm]	1050	1250
Capacity [dm ³]	-	-
Display area [m ²]	-	-
Total Display Area (TDA) [m ²]	-	-
Temp. range [°C]	(+4 ± +6°C)	(+4 ± +6°C)
Temp. class	-	-
Climate class	-	-
Energy efficiency class	-	-
Refrigerant	R448A / R449A	R448A / R449A
Rated voltage [V]	230/50Hz	230/50Hz
Rated power [W]	-	-

Standard equipment

internal cooling aggregate

refrigerant system adapted for R448A / R449A

dynamic cooling (ventilated)

external and internal housing made of coated steel sheet in a colour from the IGLOO pattern book

front panel made of laminate

exposition shelves with height adjustment

price stripes - different colors available (IGLOO pattern book)

ecological polyurethane foam insulation

interior lighting + additional illumination of each shelf - LED lights

automatic defrost

automatic condenser vaporization

electronic temperature controller with digital display (IGLOO)

condenser impurity or fan operation failure alarm

Options

external housing color - different colors available (IGLOO pattern book)

external housing made of stainless steel

interior colour - possibility of choosing the color (IGLOO pattern book)

interior and frame made of stainless steel sheet

custom color of exposition shelves on frame - (after consultation with the IGLOO Sales Department)

exposition shelves on frame made of stainless steel

powder painted evaporator

electronic temperature recorder + software

temperature recorder wire

set of wheels (castors)

FRESH 1.5

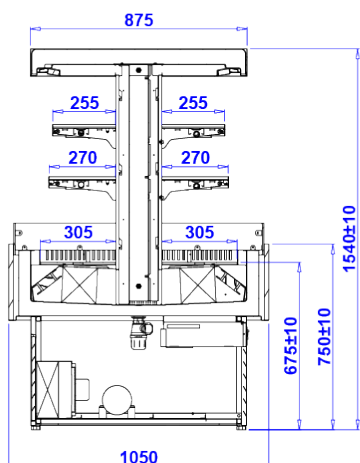

FRESH 1.85

