



Temperature range: **+1°C/+10°C**

Refrigerating unit: **External**

Refrigerant/Cooling factor: **R448A / R449A / R452A / R407F / R404A / R507**

Name	VARIANT 70H 1.0 DP/DU	VARIANT 70H 1.25 DP/DU	VARIANT 70H 1.6 DP/DU	VARIANT 70H 1.88 DP/DU	VARIANT 70H 2.50 DP/DU	VARIANT 70H 3.75 DP/DU
Code	VT100.700H.DP-c VT100.700H.DU-c	VT101.700H.DP-c VT101.700H.DU-c	VT102.700H.DP-c VT102.700H.DU-c	VT103.700H.DP-c VT103.700H.DU-c	VT104.700H.DP-c VT104.700H.DU-c	VT105.700H.DP-c VT105.700H.DU-c
Length [mm]	1000	1250	1600	1875	2500	3750
Height [mm]	2150±15	2150±15	2150±15	2150±15	2150±15	2150±15
Depth [mm]	700	700	700	700	700	700
Capacity [dm ³]	691	864	1106	1300	1728	2592
Display area [m ²]	2,40	3,00	3,84	4,51	6,00	9,00
Total Display Area (TDA) [m ²]	1,60	2,01	2,58	3,04	4,03	6,06
Temp. range [°C]	(+1 ± +10°C)	(+1 ± +10°C)	(+1 ± +10°C)	(+1 ± +10°C)	(+1 ± +10°C)	(+1 ± +10°C)
Temp. class	3M1	3M1	3M1	3M1	3M1	3M1
Climate class	3 (25°C ; 60% RH)	3 (25°C ; 60% RH)	3 (25°C ; 60% RH)	3 (25°C ; 60% RH)	3 (25°C ; 60% RH)	3 (25°C ; 60% RH)
Energy efficiency class	B	B	B	B	B	B
Refrigerant	R448A / R449A / R452A / R407F / R404A / R507	R448A / R449A / R452A / R407F / R404A / R507	R448A / R449A / R452A / R407F / R404A / R507	R448A / R449A / R452A / R407F / R404A / R507	R448A / R449A / R452A / R407F / R404A / R507	R448A / R449A / R452A / R407F / R404A / R507
Rated voltage [V]	230/50Hz	230/50Hz	230/50Hz	230/50Hz	230/50Hz	230/50Hz
Rated power [W]	177	229	280	337	459	672



The presented class applies to selected device modules. The classes for the individual modules may differ. The indication of the energy class for the selected device configuration is given on the attached label.

Standard equipment

dynamic cooling (ventilated)	
automatic off-cycle defrosting	
siphoned condensate drain	
electronic temperature controller with digital display	IGLOO
powder coated display area	IGLOO pattern book
rows of adjustable shelves	
LED lighting	upper internal - IGLOO pattern book
energy saving EC fans	
powder coated external housing	IGLOO pattern book
price stripes	IGLOO pattern book
manual night blind	not included for variants DP/DU/DR
shelf fence	
mechanical expansion valve	HFC, HFO/HFC
bottom outlets of the cooling circuitry	
ecological polyurethane foam insulation	

Options

powder coated side panels - selectable colour (IGLOO pattern book)	
powder coated side panels with mirror - selectable colour (IGLOO pattern book)	
double combined glass side panels - selectable colour (IGLOO pattern book)	
powder coated partition panel with mirrors - selectable colour (IGLOO pattern book)	
fixed partition made of plexiglass	
powder coated display area - custom powder - (after consultation with the IGLOO Sales Department)	
INOX display area	
INOX AISI304 display area	
powder coated external housing - custom powder - (after consultation with the IGLOO Sales Department)	
INOX external housing	
INOX AISI304 external housing	
additional shelf LED lighting - selectable colour (Igloo pattern book)	
additional vertical LED lighting (variants DP/DU)- selectable colour (Igloo pattern book) model 1.0 / 1.25 - 2 pcs. ; 1.6 / 1.88 / 2.50 - 4 pcs. ; 3.75 - 6 pcs.	
top panel illuminated with LED light - different plexiglass colors available (IGLOO pattern book)	
top mirrors	
meat hooks - long	
electric night blind	
powder painted evaporator	
automatic defrost	
condensate pump (up to 0,6m height)	
top outlets of the cooling circuitry	
electronic expansion valve*	
cooling system adopted to factor R744 (CO2) (only with electronic expansion valve)*	
*more information - IGLOO sales department	

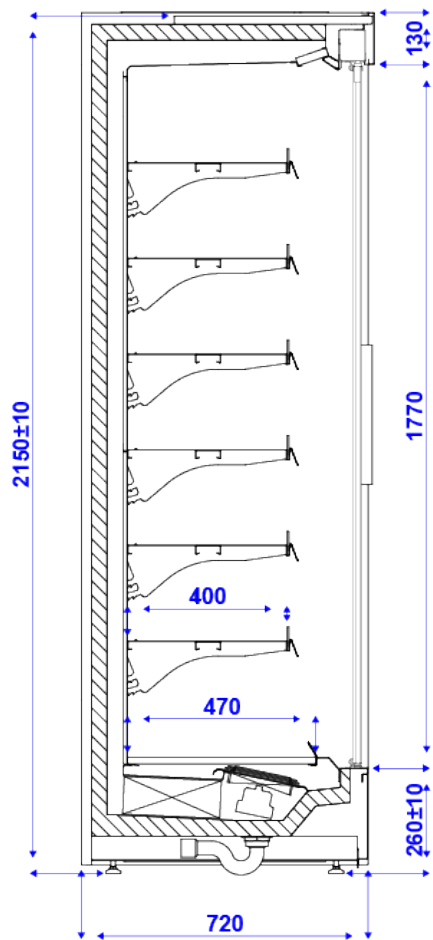

VARIANT 70H.DU REMOTE